

NPN middle stage variant
Figure 2

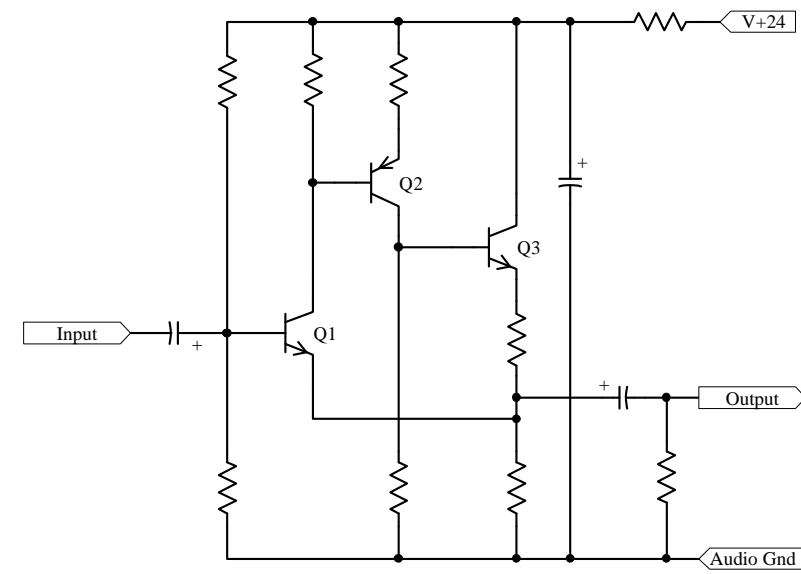

PNP middle stage variant
Figure 3

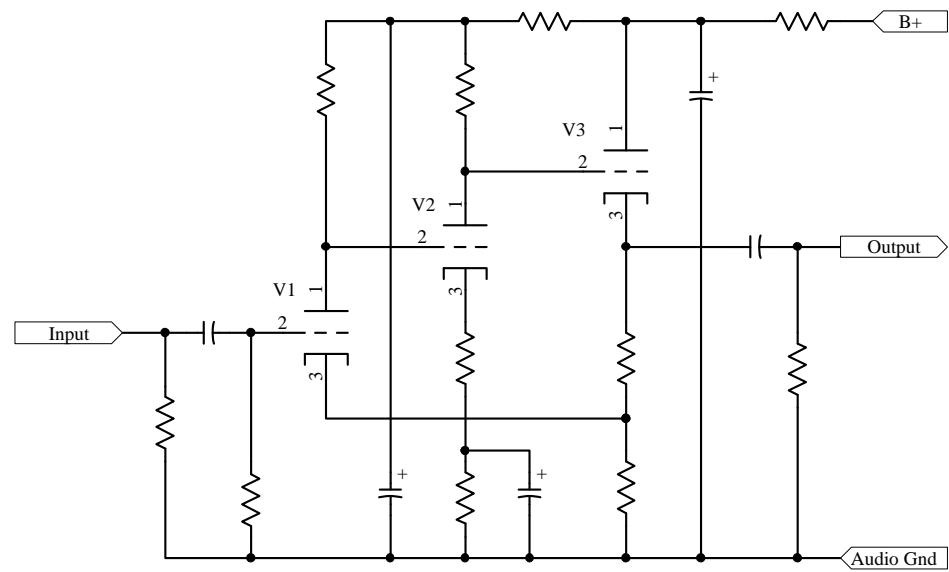

Vacuum tube example, from John Linsley Hood
Figure 1

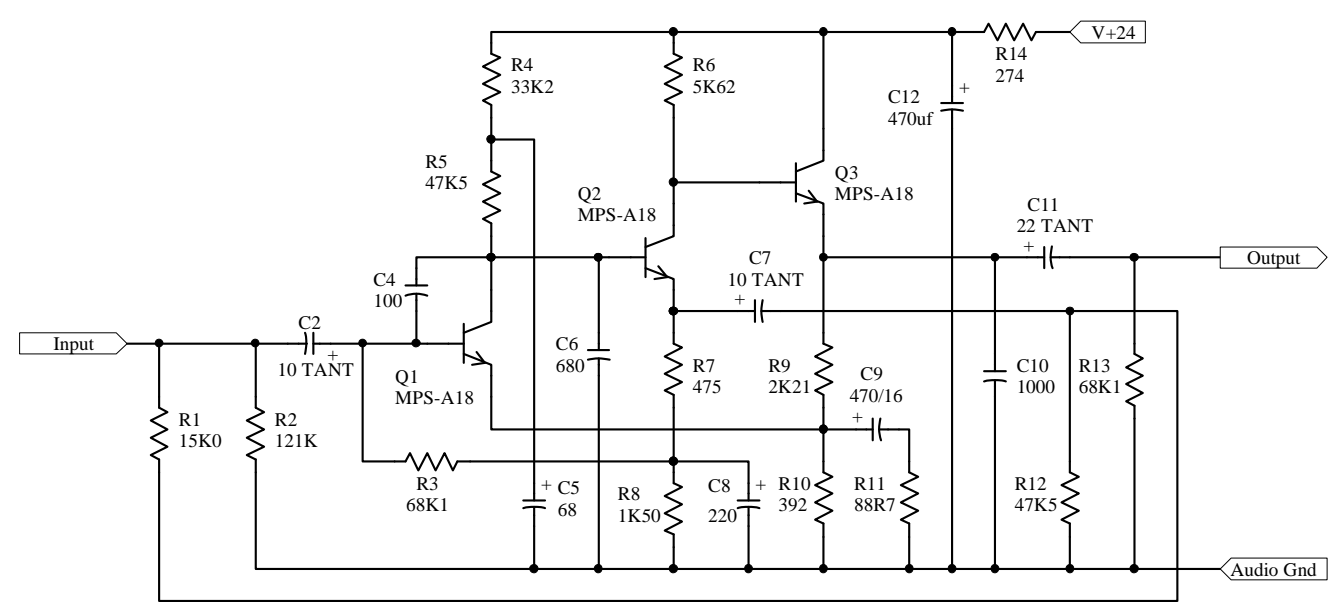

As used by Great River
Figure 4

Ring of three amplifier examples

Title		
Size	Number	Revision
B		
Date:	10/8/2014	Sheet of
File:	C:\GRE\Ring_of_three.SchDoc	Drawn By: